



# ***Giga Test Labs***

**POST OFFICE BOX 1927 CUPERTINO, CA 95015  
TELEPHONE (408) 996-7500 FAX (408) 996-7539**

**TECKNIT**

**0.5 MM PITCH LGA SOCKET**

**Final Report**

**March 24, 1999**

**Electrical Characterization  
0.05 - 3.05 GHz**

# Table of Contents

<b>Subject</b>	<b>page</b>
Table of Contents.....	ii
Summary.....	iii
Objective.....	iii
Methodology .....	iii
Measurement system .....	iii
Equivalent-circuit model.....	iii
Figure 1 - LGA socket equivalent-circuit diagram.....	iv
Element definitions .....	iv
Element values .....	iv
Table 1 - Element values for 0.5mm pitch LGA socket .....	iv
Conclusions .....	v
Figure 2 - Bandwidth measurement .....	v
Appendix .....	vi

# Summary

## Objective

The Tecknit LGA socket (0.5mm pitch) was measured at GigaTest Labs to assess their its performance. A SPICE-compatible lumped element models was derived from the measured data. Also, its high-speed performance limits were determined.

## Methodology

The LGA socket was mounted onto a custom PCB, designed to exhibit low parasitics and allow the use of coplanar probes. A second PCB (called surrogate package) with measurement standard patterns was mounted inside the socket. This allows pins to be measured under three conditions (open, shorted and thru). The HP MDS (Microwave Design System) software was then used to extract an equivalent-circuit model which is SPICE compatible.

## Measurement system

All measurements were taken using a high-frequency measurement system. This consists of a Hewlett-Packard 8510C network analyzer & GGB Picoprobes™ 450  $\mu\text{m}$  pitch. The HP 8510C network analyzer is a frequency domain instrument. The measurements are taken as scattering parameters (a.k.a. s-parameters). The HP8510C has great calibration capabilities, which make it the most accurate high-frequency instrument available. For this work the short-open-load-thru (SOLT) calibration was used. The GGB Picoprobes provide a high-quality 50  $\Omega$  path from the network analyzer and cables to the DUT.

## Equivalent-circuit model

Figure 1 shows the topology used to model the 0.5mm LGA socket. The measurements are taken from the PCB end, shown with ports 1 & 2. The surrogate package replaces the LGA package. The measurement standards are connected on either side of capacitor  $C_{21b}$ .

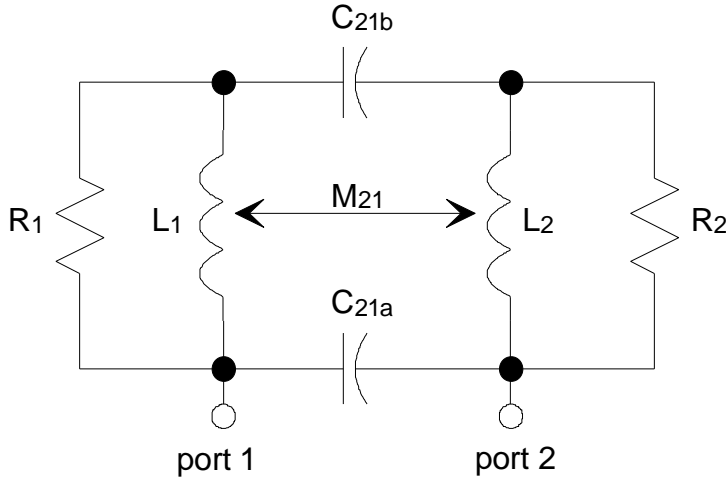

**Figure 1 - LGA socket equivalent-circuit diagram**

**Element definitions**

- L<sub>1</sub>, L<sub>2</sub>:** pin self-inductance
- M<sub>21</sub>:** mutual-inductance between adjacent pins
- R<sub>1</sub>, R<sub>2</sub>:** shunt-resistance of inductors L<sub>1</sub> and L<sub>2</sub>, used to model high-frequency loss due to skin effect and dielectric loss
- C<sub>21a</sub>:** mutual-capacitance between adjacent pins (PCB side)
- C<sub>21b</sub>:** mutual-capacitance between adjacent pins (LGA side)

**Element values**

The LGA socket model is valid from DC to 3.05 GHz. The measured and modeled transmission response agrees within 0.1 dB. A model was extracted for four types of pins: adjacent field pins, field pins oriented diagonally, edge pins and corner pins.

**Table 1 - Element values for 0.5mm pitch LGA socket**

pins	L <sub>1</sub> & L <sub>2</sub> (nH)	M <sub>21</sub> (nH)	R <sub>1</sub> & R <sub>2</sub> (Ω)	C <sub>21a</sub> (pF)	C <sub>21b</sub> (pF)
field adjacent	0.79	0.10	400	0.020	0.035
field diagonal	0.79	0.01	400	0.008	0.008
edge adjacent	0.90	0.11	450	0.030	0.030
corner adjacent	1.00	0.12	500	0.030	0.040

## Conclusions

1. The bandwidth for the LGA socket was determined from a loop-thru measurement on two adjacent pins. The nearest row of pins was grounded (see figure 2). The 1 dB bandwidth for each socket was greater than 10 GHz (highest measured frequency). For the actual measured data please see the Appendix.

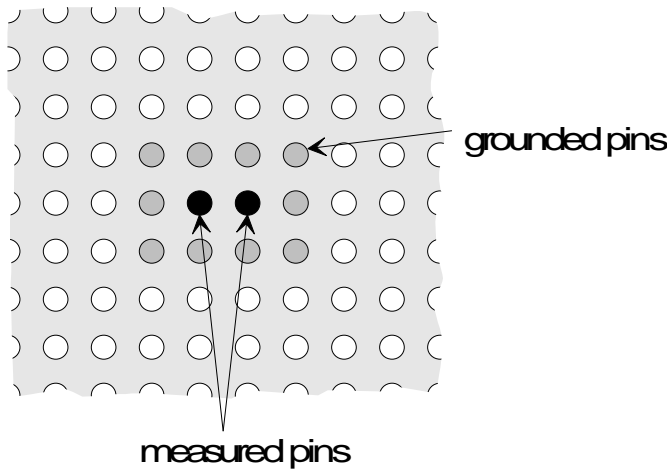

**Figure 2 - Bandwidth measurement**

2. The model bandwidth is DC-3.05 GHz, which will handle signals with 125 ps edges.

# Appendix

The appendix shows the measured and simulated output data.

<b>Measured and simulated data</b>	<b>page</b>
Tecknit LGA socket (0.5mm pitch) .....	7
Open measurement .....	7
Shorted measurement .....	8
Loop-thru measurement .....	9
Loop-thru bandwidth measurement (10 GHz).....	10

## Tecknit LGA socket (0.5mm pitch) - Open measurement on adjacent pins

Reflection response - meas (triangle) vs sim (square)

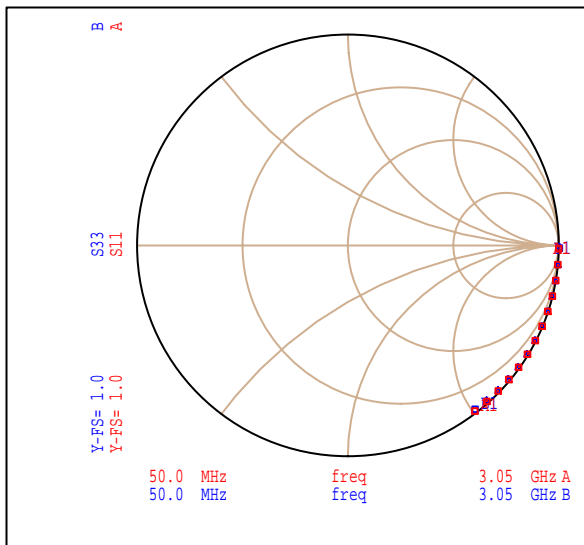

Crosstalk between adjacent pins - meas (solid) vs sim (square)

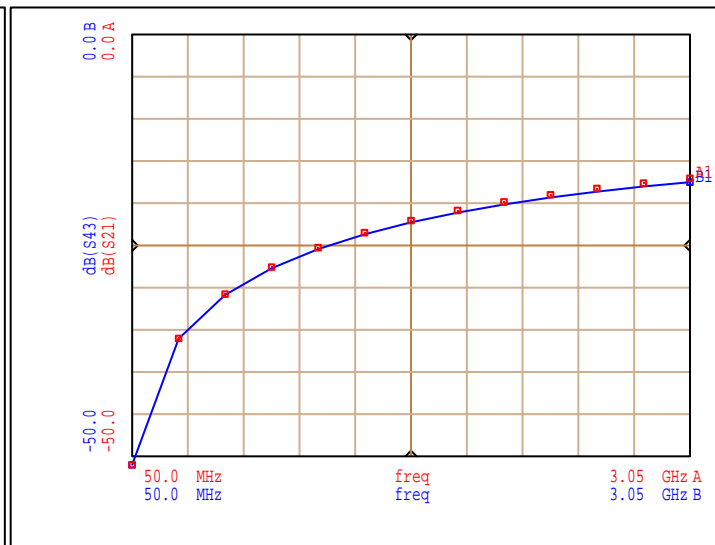

Reflection response - meas (triangle) vs sim (square)

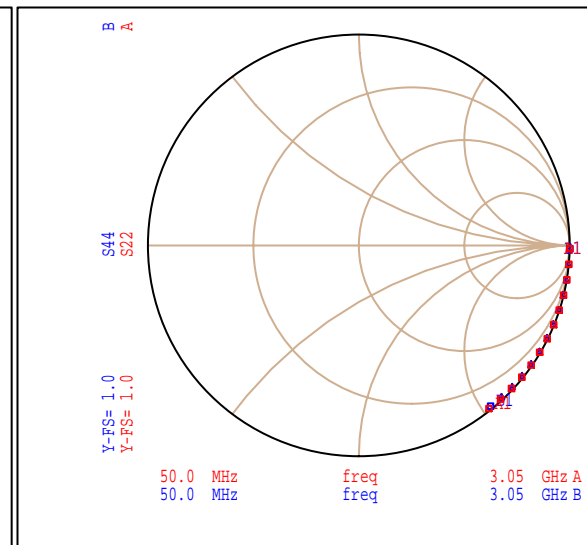

# Tecknit LGA socket (0.5mm pitch) - Shorted measurement on adjacent pins

Reflection response - meas (triangle) vs sim (square)

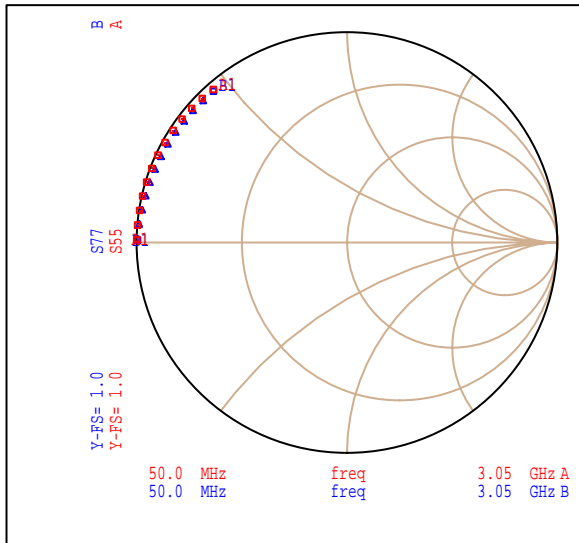

Crosstalk between adjacent pins - meas (solid) vs sim (square)

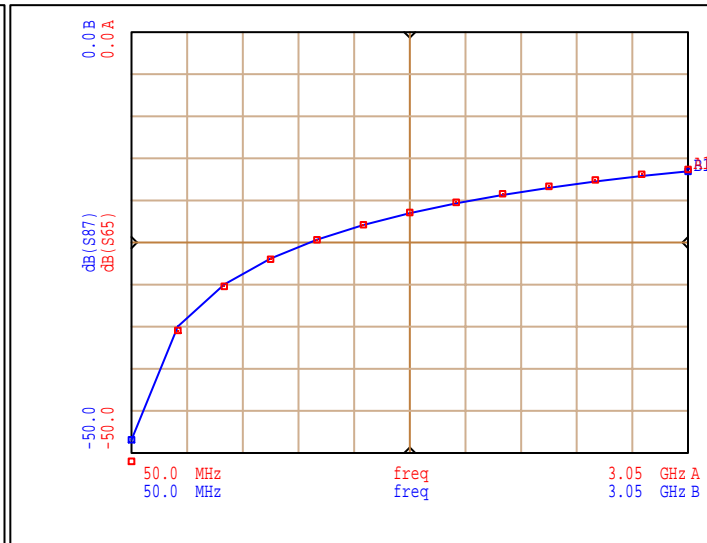

Reflection response - meas (triangle) vs sim (square)

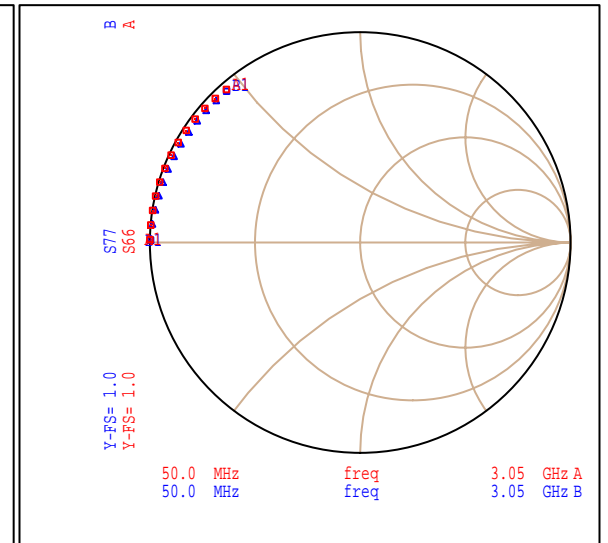

# Tecknit LGA socket (0.5mm pitch) - Thru measurement on adjacent pins

Reflection response - meas (solid) vs sim (square)

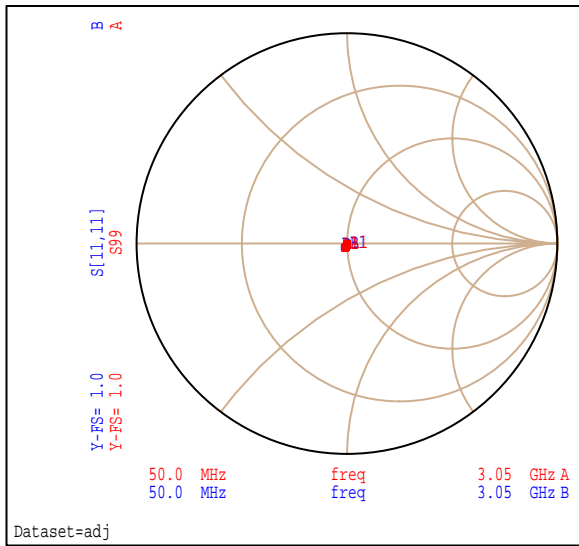

Transmission between adjacent pins - meas (solid) vs sim (square)

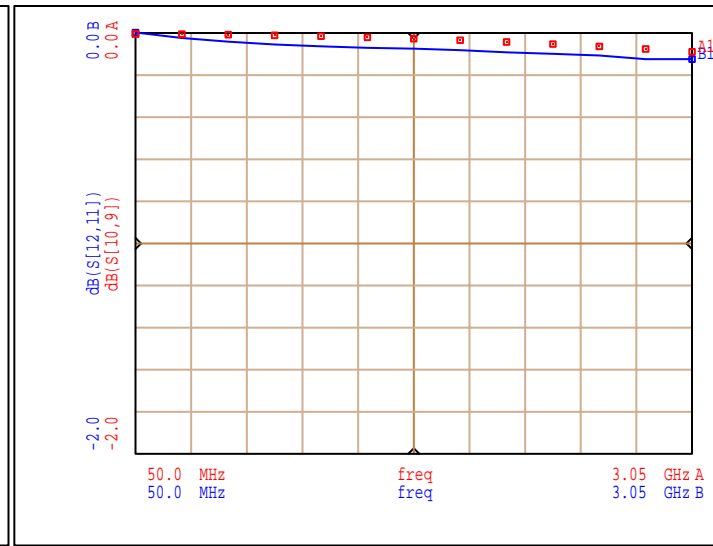

Reflection response - meas (solid) vs sim (square)

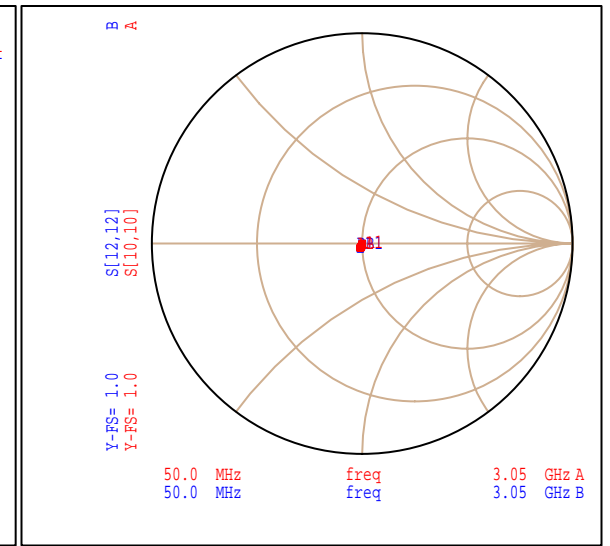

# Tecknit LGA socket (0.5mm pitch) - Loop-thru measurement

